



# GRANITE Elite® — 30 TON WRECKER

DEFENSE, LLC



## TECHNICAL SPECIFICATIONS— GRANITE ELITE® 30 TON WRECKER

<b>Transport Type/ Application:</b>	Wrecker, Class C Heavy Vocational
<b>Engine:</b>	13 Liter, MP8 440 Maxicruise 440HP (330kW), 1655lb/ft torque (2244Nm) Mack Powerleash Engine Brake V-MAC IV Electronics System Pedigreed Protection Plan
<b>Wheel Configuration:</b>	6x4
<b>Fuel Capacity:</b>	Left Hand – 50gal (189L), steel Right Hand – 50gal (189L), steel
<b>Driveline:</b>	Meritor Heavy Duty
<b>Transmission:</b>	Allison 4500 RDS Gen 4 with prognostics, 6-speed
<b>Brake System:</b>	Meritor “S” Cam Q-Plus, 16.5x6 Cam-front Meritor Heavy Duty Q-Plus, 16.5x7 Cam-rear Bendix ABS, 4S/4M system
<b>Front Axle/ Suspension:</b>	Mack FXL20 (wide pivot center) 20,000lb (9,100kg) rating Taperleaf spring suspension, axle-back position
<b>Rear Axles/ Suspension:</b>	Raydan AL520 Air Link, 52,000lb (23,587kg) rating Air ride walking beam 5.95 carrier ratio
<b>Front/Rear Tires:</b>	Michelin XZUS 315/80R22.5L (All position)
<b>Frame:</b>	11.1mm x 300mm x 90mm w/ steel reinforcement section 241” (612 cm) wheelbase 257” (653 cm) platform 82” (208 cm) overhang
<b>Driver Seat:</b>	Air, Bostrom Talladega 915 (mid-back)
<b>Passenger Seat:</b>	Mack Fixed (mid-back)

<b>Fan Drive:</b>	Behr electronic modulating
<b>Electronics:</b>	V-MAC IV routine maintenance monitoring system Body Link II interface
<b>Air System:</b>	Meritor/Wabco Air Dryer
<b>Mirrors (side):</b>	Aerodynamic body colored, heated, motorized
<b>Lighting:</b>	Halogen flush headlights Flasher type signal lights Body marker lights
<b>Starter:</b>	12V, Gear reduction
<b>Alternator:</b>	12V, 160 Amp, brush type
<b>Batteries (3):</b>	Mack 12V, 650 cold cranking amps (CCA)
<b>Cab Interior:</b>	4 dome lights Dual auxiliary power outlets 3 overhead storage bins with netting
<b>General Wrecker Specifications:</b>	Aluminum sub structure with composite panels Built in storage and chain racks Stainless steel latches with gas spring door assist 2-stage integrated hydraulic extendable boom Passenger side controls with 2 remote plug in locations Emergency engine stop (passenger and driver side) Hydraulic rear spades with integrated recovery anchors Dual 25,000 lb (11,340 kg) planetary winches
<b>Paint:</b>	Chassis– urethane base coat, Desert Tan Cab exterior– single color, Desert Tan
<b>Air Compressor/ Air Cleaner</b>	Meritor/Wabco 318 (18.7 cfm) 11” (28 cm) Single element, Donaldson steel
<b>GVW:</b>	72,000 lbs (32,659 kg)
<b>Spare Tire:</b>	Spare tire/carrier on RH frame rail

**CUSTOMIZED OPTIONS AVAILABLE TO MEET MISSION REQUIREMENTS**



DEFENSE, LLC

### 30 TON WRECKER CHASSIS SPECIFICATIONS

**JERR-DAN**  
RUN HARD<sup>®</sup>

An Oshkosh Corporation Company

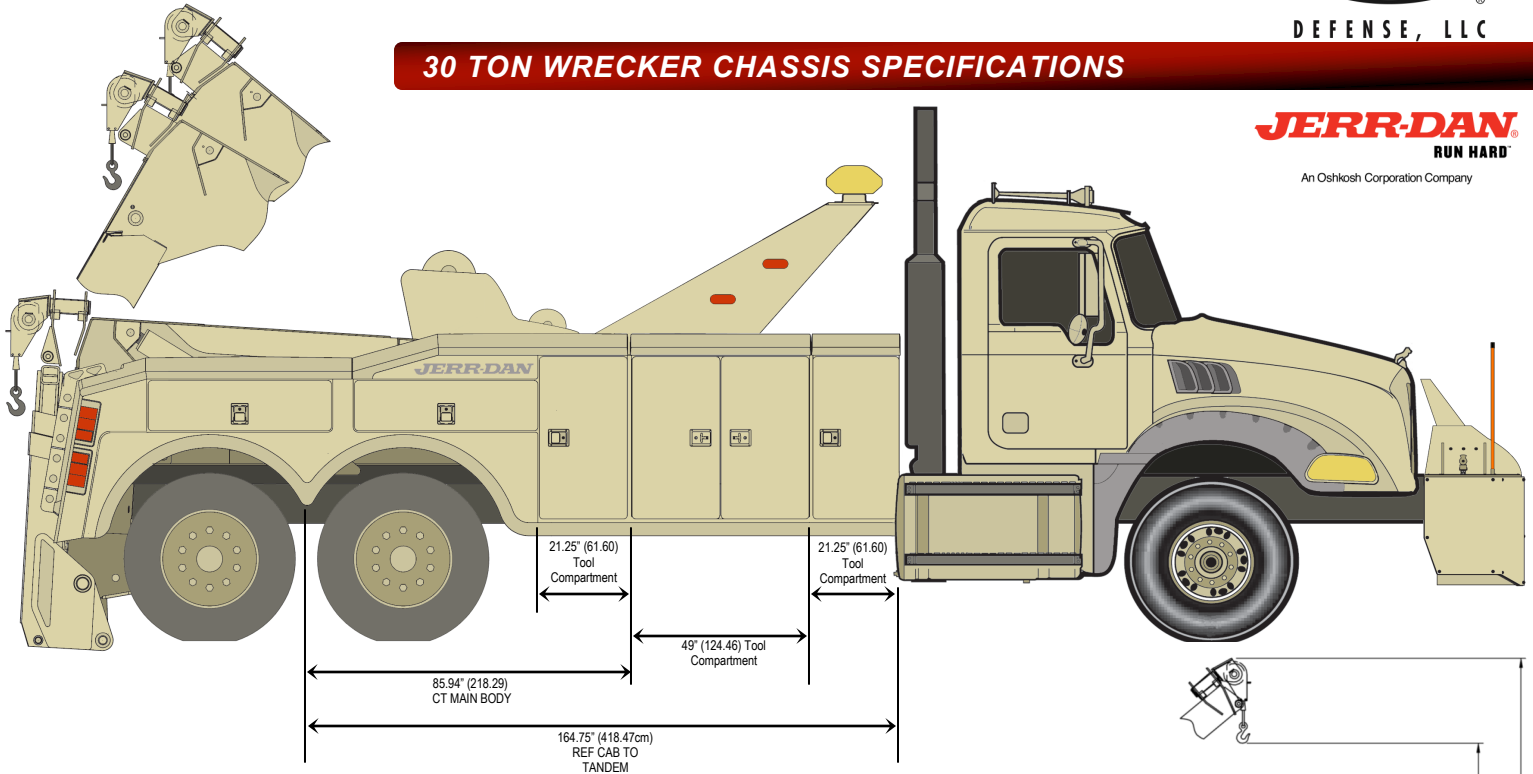

### TOP 5 REASONS TO BUY A JERR-DAN WRECKER

#### HDL 600/350 30-Ton Integrated Wrecker

1. 60,000 lb (27,360kg) rated boom capacity offers a low profile, and it can be raised and extended without repositioning the underlift. A nice feature when you are in a hurry.
2. Optional dual controls let you operate wrecker and underlift from both sides of the wrecker. Hydraulic system pressure gauges on the passenger side let you keep an eye on system performance.
3. Dual 25,000 lb (11,340kg) winches with 200' (61m) of wire rope are independently controlled. Full power for both winches is available when they are operated together.
4. The winches move with the boom so you don't have to reposition them every time you move the boom.
5. Independently controlled dual rear jacks quickly convert to spades for recovery work and back again for lifting.

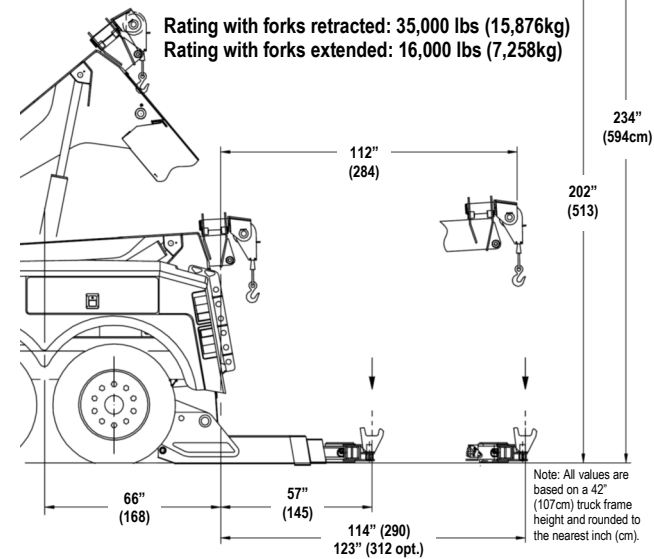

Rating with forks retracted: 35,000 lbs (15,876kg)  
Rating with forks extended: 16,000 lbs (7,258kg)

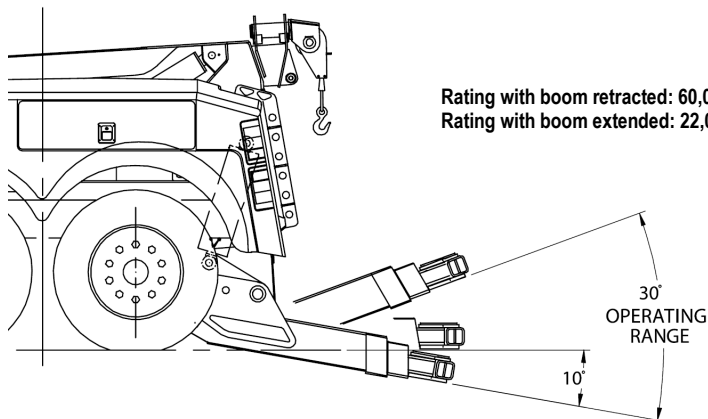

Rating with boom retracted: 60,000 lbs (27,360kg)  
Rating with boom extended: 22,000 lbs (9,979kg)

### SLEEK, LIGHTWEIGHT, AND VERY HEAVY DUTY

#### HDL 600/350 30-Ton Integrated Wrecker

This 30-ton wrecker handles some seriously heavy loads. With an effective reach of nearly 10 (3.05m) feet, the integrated underlift provides negative and positive tilt. A composite/aluminum body and Class-A paint finish provide a striking look and long life.

Jerr-Dan's 30-ton integrated wrecker combines lighter weight with heavy performance. This powerhouse lets you tackle tough jobs. And it offers the uncompromising quality and high-performance you count on from Jerr-Dan.

### CUSTOMIZED OPTIONS AVAILABLE TO MEET MISSION REQUIREMENTS

For more information:  
Mack Defense Headquarters  
2402 Lehigh Parkway South  
Allentown, PA 18103  
Tel: (336) 291-9301 Fax: (336) 291-9302  
MackDefense@macktrucks.com



www.mackdefense.com

©2012 Mack Trucks, Inc. All rights reserved. Mack, Mack and the Bulldog design, Granite Elite, Taperleaf, and MP8, are trademarks of Mack Trucks, Inc. All other trademarks are the property of their respective companies